

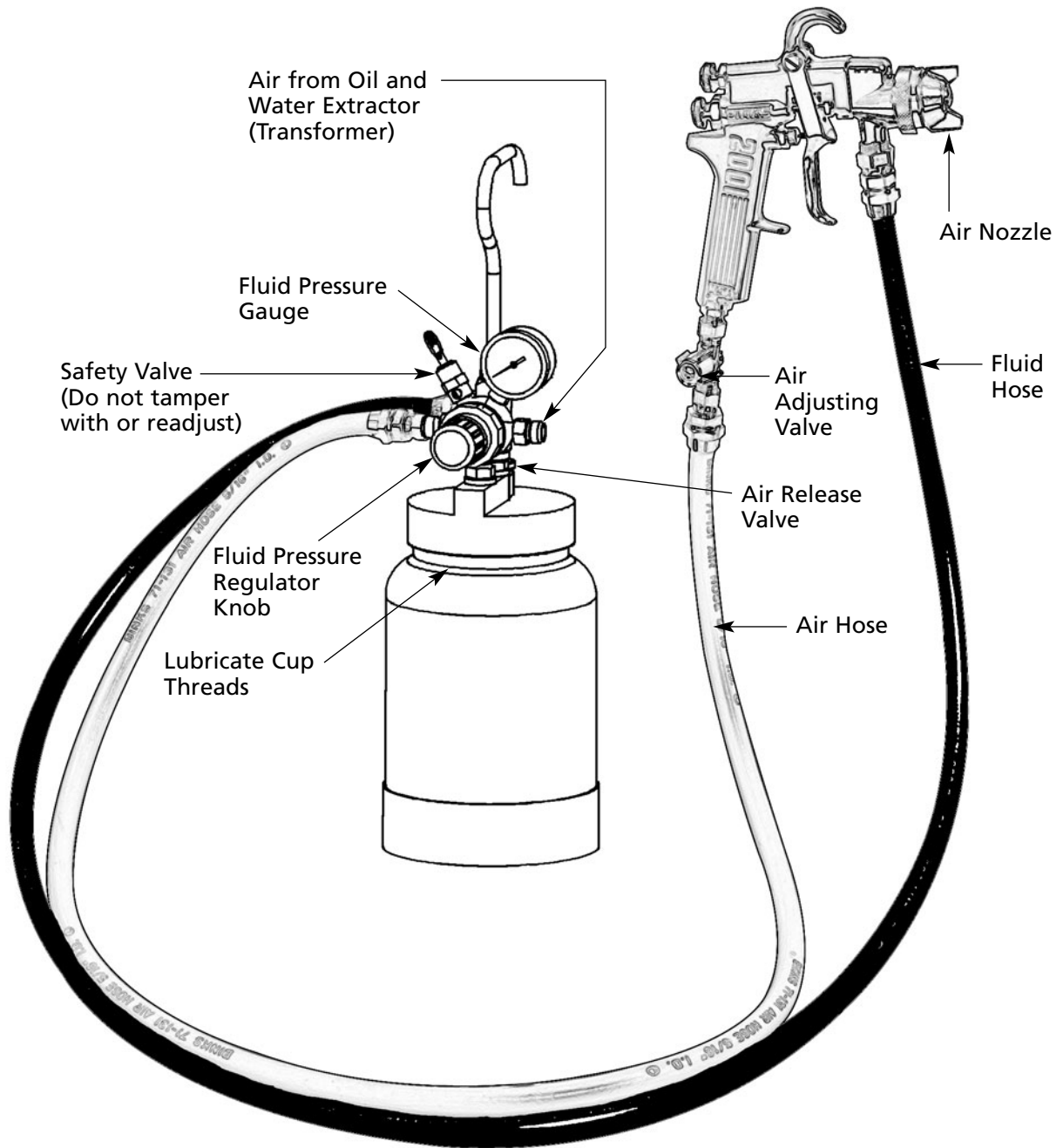

Binks Model 80-295 (2 QT.) "STEADI-GRIP" PRESSURE CONTAINER



Replaces
Part Sheet
77-2823R

Part
Sheet
77-2823R-1

In this part sheet, the words **WARNING**, **CAUTION** and **NOTE** are used to emphasize important safety information as follows:

⚠ WARNING
 Hazards or unsafe practices which could result in severe personal injury, death or substantial property damage.

⚠ CAUTION
 Hazards or unsafe practices which could result in minor personal injury, product or property damage.

NOTE
 Important installation, operation or maintenance information.

⚠ WARNING

Read the following warnings before using this equipment.



READ THE MANUAL
 Before operating finishing equipment, read and understand all safety, operation and maintenance information provided in the operation manual.



WEAR SAFETY GLASSES
 Failure to wear safety glasses with side shields could result in serious eye injury or blindness.

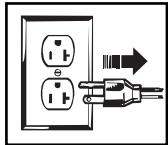

DE-ENERGIZE, DISCONNECT AND LOCK OUT ALL POWER SOURCES DURING MAINTENANCE
 Failure to De-energize, disconnect and lock out all power supplies before performing equipment maintenance could cause serious injury or death.



OPERATOR TRAINING
 All personnel must be trained before operating finishing equipment.



EQUIPMENT MISUSE HAZARD
 Equipment misuse can cause the equipment to rupture, malfunction, or start unexpectedly and result in serious injury.

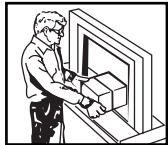

KEEP EQUIPMENT GUARDS IN PLACE
 Do not operate the equipment if the safety devices have been removed.

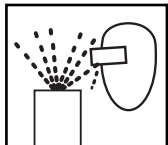

PROJECTILE HAZARD
 You may be injured by venting liquids or gases that are released under pressure, or flying debris.

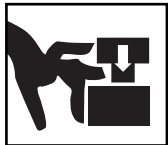

PINCH POINT HAZARD
 Moving parts can crush and cut. Pinch points are basically any areas where there are moving parts.



AUTOMATIC EQUIPMENT
 Automatic equipment may start suddenly without warning.



INSPECT THE EQUIPMENT DAILY
 Inspect the equipment for worn or broken parts on a daily basis. Do not operate the equipment if you are uncertain about its condition.



NEVER MODIFY THE EQUIPMENT
 Do not modify the equipment unless the manufacturer provides written approval.



KNOW WHERE AND HOW TO SHUT OFF THE EQUIPMENT IN CASE OF AN EMERGENCY



PRESSURE RELIEF PROCEDURE
 Always follow the pressure relief procedure in the equipment instruction manual.



NOISE HAZARD
 You may be injured by loud noise. Hearing protection may be required when using this equipment.



STATIC CHARGE
 Fluid may develop a static charge that must be dissipated through proper grounding of the equipment, objects to be sprayed and all other electrically conductive objects in the dispensing area. Improper grounding or sparks can cause a hazardous condition and result in fire, explosion or electric shock and other serious injury.

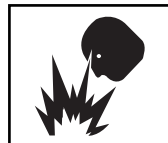

FIRE AND EXPLOSION HAZARD
 Never use 1,1,1-trichloroethane, methylene chloride, other halogenated hydrocarbon solvents or fluids containing such solvents in equipment with aluminum wetted parts. Such use could result in a serious chemical reaction, with the possibility of explosion. Consult your fluid suppliers to ensure that the fluids being used are compatible with aluminum parts.

FOR FURTHER SAFETY INFORMATION REGARDING BINKS AND DEVILBISS EQUIPMENT, SEE THE GENERAL EQUIPMENT SAFETY BOOKLET (77-5300).

Binks Model 80-295 (2 QT.) "STEADI-GRIP" PRESSURE CONTAINER

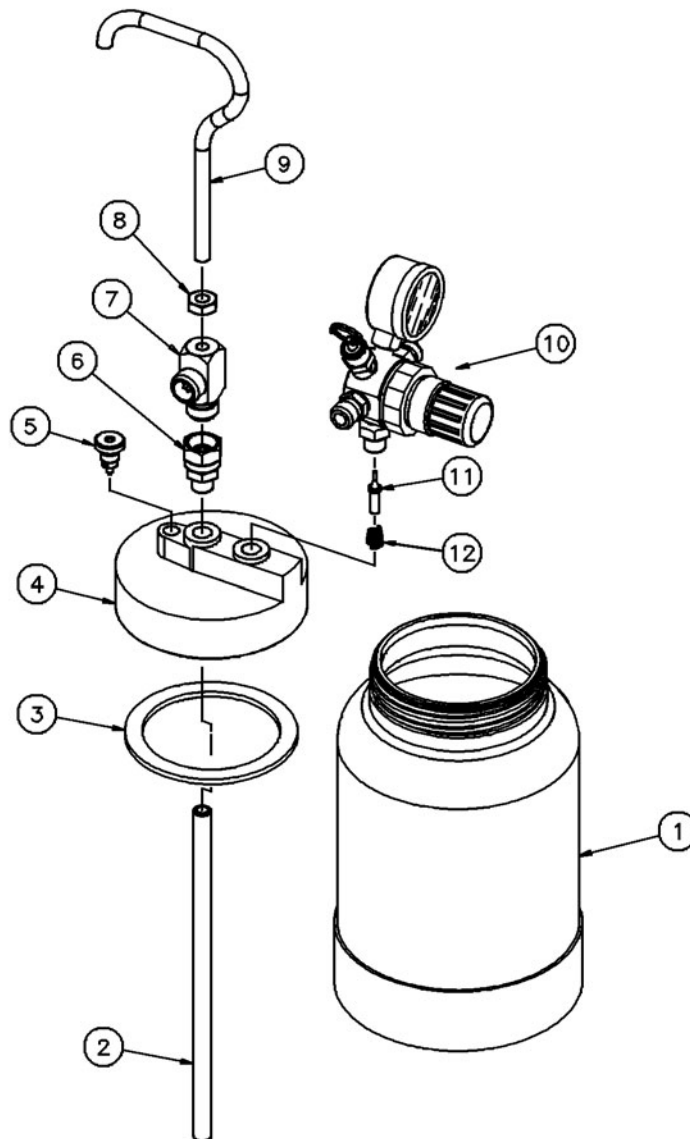

PARTS LIST

When ordering, please specify Part No.

| ITEM NO. | PART NO. | DESCRIPTION | QTY. | ITEM NO. | PART NO. | DESCRIPTION | QTY. |
|----------|-----------|-----------------------------|------|----------|----------|--|------|
| 1 | 80-4 | CUP, 2 QUART | 1 | 10 | 85-440 | AIR REGULATOR ASSEMBLY | 1 |
| 2 | 80-34 | TUBE, MATERIAL | 1 | | | (MAX. 50 PSI FLUID PRESSURE) | |
| 3 | 80-11* | GASKET, TRI SEAL FOAM | 1 | | | (SEE PART SHEET 2817) | |
| 4 | 80-297 | COVER | 1 | 11 | 80-267 | VALVE..... | 1 |
| 5 | 80-12 | AIR RELEASE VALVE | 1 | 12 | 60-7 | SPRING | 1 |
| 6 | 72-1022 ▲ | CENTERPOST ASSEMBLY | 1 | 13 | 80-45 | OPTIONAL GASKET, LEATHER | — |
| 7 | 80-33 | OUTLET | 1 | | | (ORDER SEPARATELY) | |
| 8 | 20-353 | JAM NUT, 5/16-18 | 1 | 14 | 85-441 | 2ND REGULATOR KIT | — |
| 9 | 83-1899 | HANDLE | 1 | | | (MAX. 50 PSI FOR ATOMIZING AIR CONTROL) (ORDER SEPARATELY) | |

* Available in quantity pack. For Tri-Seal Gaskets, order 80-11-5 (qty. of 5).

▲ Available from Industrial Finishing distributors only.

OPERATION AND CLEANING

External Mix Air Nozzle Application

OPERATION:

1. Connect hose as shown in diagram on front page.
2. Fill cup with *strained* fluid mixed in accordance with manufacturer's recommendations on label of container.
3. Fasten cover securely.
4. Close air adjusting valve by turning clockwise.
5. Set air pressure at oil and water extractor (transformer) to between 35 and 80 PSI, depending upon atomization desired.
6. Set regulator on pressure cup to approximately 10 PSI for enamels; 5 PSI for lacquers. (Turn knob clockwise to increase pressure; to reduce pressure, turn knob counter-clockwise. Always release air in cup by momentarily opening air release valve on cover when attempting to reduce pressure.)
7. Open air adjusting valve.
8. With trigger fully pulled back, make several fast spray strokes against a flat surface. After adjustment of pressure, proper atomization will be indicated by an even distribution of finely divided paint particles.

IMPORTANT

The most efficient atomization air pressure is the lowest air pressure that will properly atomize the paint. This will minimize the overspray, deposit more paint on the surface and eliminate paint waste.

If a faster coverage is necessary, first increase fluid pressure and then adjust atomization air pressure. If a slower coverage is more desirable, first reduce the fluid pressure and then adjust atomization air pressure. Always attempt to maintain the lowest pressures for maximum efficiency.

For ease of removing cup cover and to prevent leakage, always thoroughly grease the threads on the cup.

⚠ CAUTION

If the cup is accidentally tipped over or held at too great an angle, fluid will load up the underside of cup cover, and leak into regulator. In the event this happens, clean immediately!

Internal Mix Air Nozzle Application

OPERATION:

NOTE

The steps are the same as with the external mix nozzles, except the air and fluid pressure settings are different.

The internal mix air nozzle accomplishes atomization by mixing the air and fluid within the air nozzle.

1. Close air adjusting valve by turning clockwise.
2. Set air pressure at oil and water extractor (transformer) to approximately 45 PSI.
3. Open air adjusting valve and allow air to enter the gun.
4. Set fluid pressure at 20 lbs. and adjust higher or lower until desired atomization is effected. Air pressure should be alternately adjusted.

CLEANING

1. Open air release valve on pressure cup cover.
2. Reduce pressure in cup until gauge reads zero, (turn knob counter-clockwise).
3. Loosen cup cover and set fluid tube on angle in cup.
4. Loosen air nozzle two turns, place cloth over nozzle and pull the trigger to force paint into cup.
5. Remove cover and clean cup and cover thoroughly.
6. With approximately 1/4 to 1/2 cup of clean solvent, attach cover and set fluid pressure at approximately 10 PSI.
7. Close air adjusting valve at spray gun.
8. Trigger gun and allow solvent to flow into a container until it flows clear.
9. Remove solvent, then clean air nozzle. If any dirt appears in orifice, clean with tooth pick Blow nozzle and cup dry. Replace nozzle and cover loosely.

⚠ CAUTION

Never use a wire or metal object to clean the air nozzle—they may damage the nozzle and cause faulty spray.

NOTE

Never allow solvent to remain in cup; solvent vapors tend to reduce service life of gasket. Separate storage of cup and cover recommended.

WARRANTY

This product is covered by Binks' 1 Year Limited Warranty.

Binks Worldwide Sales and Service Listing: www.binks.com

ITW Industrial Finishing

Binks has authorized distributors throughout the world. For technical assistance or the distributor nearest you, see listing below.

U.S./Canada Technical Service Office:

195 Internationale Blvd., Glendale Heights, IL 60139
Toll-Free Telephone: 1-888-992-4657 (U.S.A. and Canada only)
Toll-Free Fax: 1-888-246-5732

77-2823R-1 Revisions: (P3) Updated Parts List.



An Illinois Tool Works Company