

# Merkur<sup>®</sup> Non-Heated Airspray Packages

3A7003B

EN

*For high-performance finishing and coating applications in hazardous or non-hazardous locations. For professional use only.*

See page **Models**, page 4, for model information. See **Technical Specifications**, page 30, for maximum working pressures.



## Important Safety Instructions

Read all warnings and instructions in this manual before using the equipment.  
Save these instructions.

**Cart Mount**

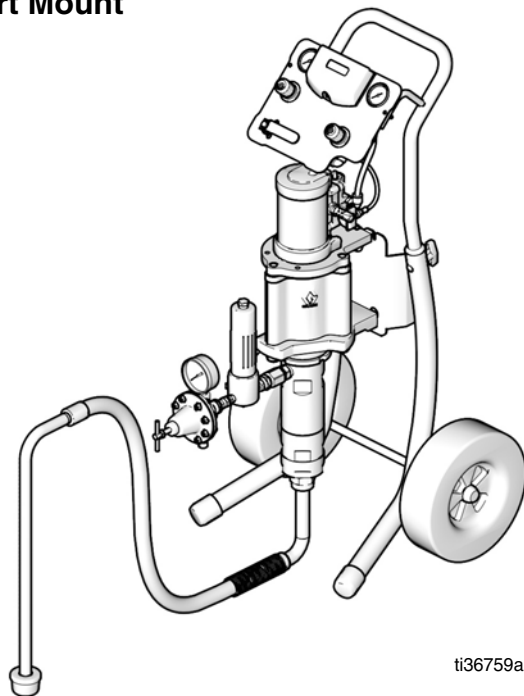

ti36759a

**Wall Mount**

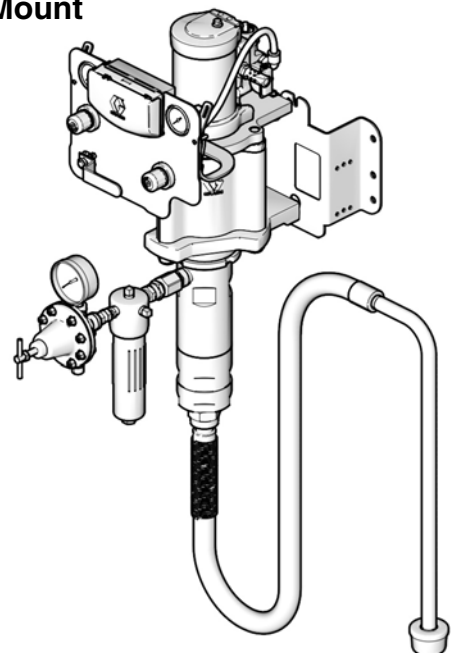

ti36760a

# Contents

<b>Related Manuals</b> .....	<b>3</b>	<b>Troubleshooting</b> .....	<b>16</b>
<b>Models</b> .....	<b>4</b>	<b>DataTrak Controls and Indicators</b> .....	<b>17</b>
Merkur 3:1 Packages		<b>DataTrak Operation</b> .....	<b>18</b>
(G03Wxx and G03Cxx) .....	5	Setup Mode .....	18
<b>Warnings</b> .....	<b>6</b>	Run Mode .....	18
<b>Typical Installation</b> .....	<b>9</b>	Replace DataTrak Battery or Fuse .....	22
General Information .....	10	<b>Parts</b> .....	<b>24</b>
Prepare the Operator .....	10	Cart Mount .....	24
Prepare the Site .....	10	Wall Mount .....	25
Wall Mount Packages .....	10	<b>Kits</b> .....	<b>27</b>
Components .....	11	Wall Mount Kit 24A578 .....	27
Air Line Accessories .....	11	Cart Mount Kit 289694 .....	27
Grounding .....	11	Pump and Gun Control Panel Kits .....	28
Setup .....	12	DataTrak .....	29
Gun Setup .....	12	Drain Valve Kit 256425 .....	29
<b>Operation</b> .....	<b>13</b>	Reinforced PTFE V-Packing Kits .....	29
Pressure Relief Procedure .....	13	<b>Wall Bracket Mounting Dimensions</b> .....	<b>30</b>
Flush the Pump Before First Use .....	13	<b>Technical Specifications</b> .....	<b>30</b>
Wet Cup .....	13	<b>Graco Standard Warranty</b> .....	<b>32</b>
Prime the Pump .....	14	<b>Graco Information</b> .....	<b>32</b>
Shutdown .....	14		
<b>Maintenance</b> .....	<b>15</b>		
Preventive Maintenance Schedule .....	15		
Tighten Threaded Connections .....	15		
Flush the Pump .....	15		
Wet Cup .....	15		

## Related Manuals

Manual	Description
312792	Merkur Displacement Pump
312794	Merkur Pump Assembly
312796	NXT® Air Motor
312414	Manual, SB AirPro®, Gun
307273	Fluid Outlet Filter
313541	DataTrak Kits

# Models

Check the identification plate (ID) for the 6-digit part number of your package. Use the following matrix and tables to define the components of your package. For example, package number **G03C08** represents a Merkur package (**G**), with a 3:1 ratio pump (**03**), cart mounting (**C**), and the components shown for (**08**) in the table on page 9.

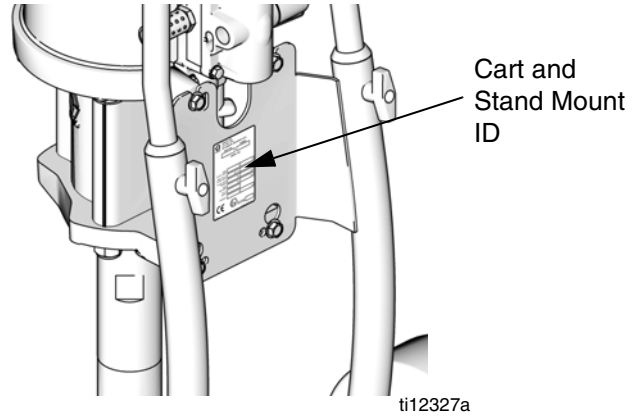
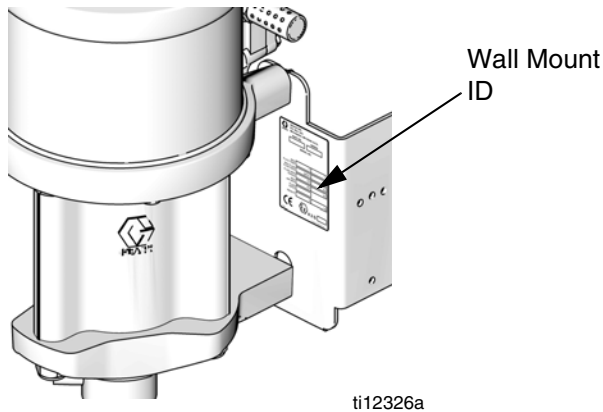

<b>G</b>	<b>03</b>		<b>C</b>		<b>08</b>
First Digit	Second and Third Digits (Ratio)		Fourth Digit (Mounting Type)		Fifth and Sixth Digit (Components Included)
<b>G</b> (Merkur Package)	<b>03</b>	3:1	<b>C</b>	Cart	See Table on pg. 5
			<b>W</b>	Wall	

# Merkur 3:1 Packages (G03Wxx and G03Cxx)

Maximum Inlet Air Pressure: 50 psi (.34 MPa, 3.4 bar)

Maximum Fluid Working Pressure: 120 psi (.83 MPa, 8.3 bar)

Model		Pump Assembly	Gun	Fluid Reg. (241976)	Air Controls	Hoses		Accessories		Data-Trak	Approvals
Wall Mount	Cart Mount				Pump and Gun	Gun Fluid Hose (25 ft.)	Gun Air Hose (25 ft.)	Siphon Kit	Fluid Filter		
G03W01	G03C01	W03EAS	None		✓			✓			◆
G03W02	G03C02	W03EBS	None		✓			✓	✓	✓	†
G03W03	G03C03	W03EAS	None		✓			✓	✓		◆
G03W04	G03C04	W03EBS	AirPro HVLP	✓	✓	✓	✓	✓	✓	✓	†
G03W05	G03C05	W03EAS	AirPro HVLP	✓	✓	✓	✓	✓	✓		◆
G03W06	G03C06	W03EBS	AirPro Conventional	✓	✓	✓	✓	✓	✓	✓	†
G03W07	G03C07	W03EAS	AirPro Conventional	✓	✓	✓	✓	✓	✓		◆
G03W08	G03C08	W03EBS	AirPro Compliant	✓	✓	✓	✓	✓	✓	✓	†
G03W09	G03C09	W03EAS	AirPro Compliant	✓	✓	✓	✓	✓	✓		◆
G03W15	G03C15	W03EAS	None								◆

◆ CE  II 2G Ex h IIB T6 Gb

† CE  II 2(1) G Ex h [ia Ga] IIA T3 Gb X

DataTrak™ Module includes agency approvals listed below.









  
Intertek  
9902471  
Class I, Div. 1,  
Group D T3A

  
2575







 II 1 G  
Ex ia IIA T3 Ga  
ITS13ATEX27862X

# Warnings

The following warnings are for the setup, use, grounding, maintenance, and repair of this equipment. The exclamation point symbol alerts you to a general warning and the hazard symbols refer to procedure-specific risks. When these symbols appear in the body of this manual or on warning labels, refer back to these Warnings. Product-specific hazard symbols and warnings not covered in this section may appear throughout the body of this manual where applicable.

 <h2 style="margin: 0;">WARNING</h2>	
   	<p><b>FIRE AND EXPLOSION HAZARD</b></p> <p>Flammable fumes, such as solvent and paint fumes, in <b>work area</b> can ignite or explode. Paint or solvent flowing through the equipment can cause static sparking. To help prevent fire and explosion:</p> <ul style="list-style-type: none"> <li>• Use equipment only in well-ventilated area.</li> <li>• Eliminate all ignition sources; such as pilot lights, cigarettes, portable electric lamps, and plastic drop cloths (potential static sparking).</li> <li>• Ground all equipment in the work area. See <b>Grounding</b> instructions.</li> <li>• Never spray or flush solvent at high pressure.</li> <li>• Keep work area free of debris, including solvent, rags and gasoline.</li> <li>• Do not plug or unplug power cords, or turn power or light switches on or off when flammable fumes are present.</li> <li>• Use only grounded hoses.</li> <li>• Hold gun firmly to side of grounded pail when triggering into pail. Do not use pail liners unless they are anti-static or conductive.</li> <li>• <b>Stop operation immediately</b> if static sparking occurs or you feel a shock. Do not use equipment until you identify and correct the problem.</li> <li>• Keep a working fire extinguisher in the work area.</li> </ul>
  	<p><b>PRESSURIZED EQUIPMENT HAZARD</b></p> <p>Fluid from the equipment, leaks, or ruptured components can splash in the eyes or on skin and cause serious injury.</p> <ul style="list-style-type: none"> <li>• Follow the <b>Pressure Relief Procedure</b> when you stop spraying/dispensing and before cleaning, checking, or servicing equipment.</li> <li>• Tighten all fluid connections before operating the equipment.</li> <li>• Check hoses, tubes, and couplings daily. Replace worn or damaged parts immediately.</li> </ul>

# ! WARNING

 	<p><b>EQUIPMENT MISUSE HAZARD</b> Misuse can cause death or serious injury.</p> <ul style="list-style-type: none"> <li>• Do not operate the unit when fatigued or under the influence of drugs or alcohol.</li> <li>• Do not exceed the maximum working pressure or temperature rating of the lowest rated system component. See <b>Technical Specifications</b> in all equipment manuals.</li> <li>• Use fluids and solvents that are compatible with equipment wetted parts. See <b>Technical Specifications</b> in all equipment manuals. Read fluid and solvent manufacturer's warnings. For complete information about your material, request Safety Data Sheets (SDSs) from distributor or retailer.</li> <li>• Do not leave the work area while equipment is energized or under pressure.</li> <li>• Turn off all equipment and follow the <b>Pressure Relief Procedure</b> when equipment is not in use.</li> <li>• Check equipment daily. Repair or replace worn or damaged parts immediately with genuine manufacturer's replacement parts only.</li> <li>• Do not alter or modify equipment. Alterations or modifications may void agency approvals and create safety hazards.</li> <li>• Make sure all equipment is rated and approved for the environment in which you are using it.</li> <li>• Use equipment only for its intended purpose. Call your distributor for information.</li> <li>• Route hoses and cables away from traffic areas, sharp edges, moving parts, and hot surfaces.</li> <li>• Do not kink or over bend hoses or use hoses to pull equipment.</li> <li>• Keep children and animals away from work area.</li> <li>• Comply with all applicable safety regulations.</li> </ul>
 	<p><b>MOVING PARTS HAZARD</b> Moving parts can pinch, cut or amputate fingers and other body parts.</p> <ul style="list-style-type: none"> <li>• Keep clear of moving parts.</li> <li>• Do not operate equipment with protective guards or covers removed.</li> <li>• Equipment can start without warning. Before checking, moving, or servicing equipment, follow the <b>Pressure Relief Procedure</b> and disconnect all power sources.</li> </ul>
	<p><b>TOXIC FLUID OR FUMES HAZARD</b> Toxic fluids or fumes can cause serious injury or death if splashed in the eyes or on skin, inhaled, or swallowed.</p> <ul style="list-style-type: none"> <li>• Read Safety Data Sheets (SDSs) to know the specific hazards of the fluids you are using.</li> <li>• Store hazardous fluid in approved containers, and dispose of it according to applicable guidelines.</li> </ul>
	<p><b>BURN HAZARD</b> Equipment surfaces and fluid that is heated can become very hot during operation. To avoid severe burns:</p> <ul style="list-style-type: none"> <li>• Do not touch hot fluid or equipment.</li> </ul>



# WARNING



## PERSONAL PROTECTIVE EQUIPMENT

Wear appropriate protective equipment when in the work area to help prevent serious injury, including eye injury, hearing loss, inhalation of toxic fumes, and burns. Protective equipment includes but is not limited to:

- Protective eyewear, and hearing protection.
- Respirators, protective clothing, and gloves as recommended by the fluid and solvent manufacturer.



## SPECIFIC CONDITIONS OF SAFE USE

Equipment must comply with the following conditions to avoid a hazardous condition which can cause fire or explosion.

- All labels and identification plates must be cleaned with a damp cloth (or equivalent).
- The electronic monitoring system is required to be grounded. See **Grounding** instructions.





# Typical Installation

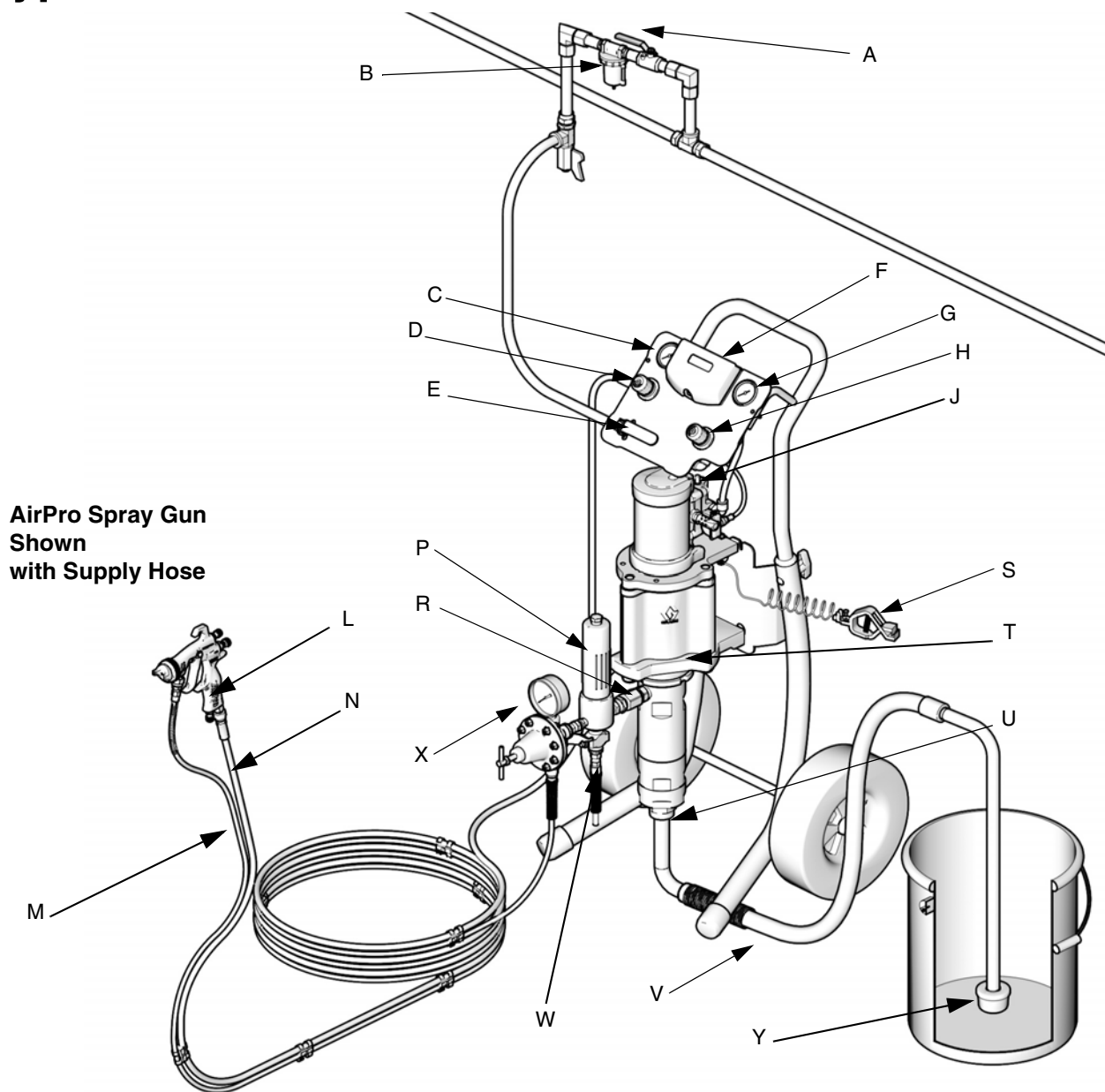

**FIG. 1. Typical Installation (Your package may not include all items shown.)**

Package configurations vary widely. See page 5 to determine the components included in your model.

- |   |   |   |  |
|---|---|---|--|
| A | Air Shutoff Valve (required)  | N | Gun Air Supply Hose                        |
| B | Air Filter  | P | Fluid Filter                               |
| C | Gun Air Pressure Gauge  | R | Pump Fluid Outlet                          |
| D | Gun Air Pressure Regulator  | S | Grounding Wire                             |
| E | Bleed-Type Master Air Valve (3/8-18 npt(f))   | T | Wet-Cup (not visible, see FIG. 3, page 13) |
| F | DataTrak  | U | Pump Fluid Inlet                           |
| G | Pump Air Pressure Gauge   | V | Suction Hose                               |
| H | Pump Air Pressure Regulator   | W | Fluid Drain Valve                          |
| J | Solenoid Release Button (DataTrak equipped packages only, not visible, see FIG. 5, page 18) | X | Fluid Regulator                            |
| L | AirPro Gun  | Y | Strainer                                   |
| M | Gun Fluid Supply Hose   |   |  |

## General Information

**NOTE:** Reference numbers and letters in parentheses in the text refer to the callouts in the figures and the parts drawing.

**NOTE:** Always use Genuine Graco Parts and Accessories, available from your Graco distributor. If you supply your own accessories, be sure they are adequately sized and pressure-rated for your system.

FIG. 1 is only a guide for selecting and installing system components and accessories. Contact your Graco distributor for assistance in designing a system to suit your particular needs.

## Prepare the Operator

All persons who operate the equipment must be trained in the operation of all system components as well as the proper handling of all fluids. All operators must thoroughly read all instruction manuals, tags, and labels before operating the equipment.

## Prepare the Site

Ensure that you have an adequate compressed air supply.

Bring a compressed air supply line from the air compressor to the pump location. Be sure all air hoses are properly sized and pressure-rated for your system. Use only electrically conductive hoses. The air hose should have a 3/8 npt(m) thread. A quick disconnect coupling is recommended.

Keep the site clear of any obstacles or debris that could interfere with the operator's movement.

Have a grounded, metal pail available for use when flushing the system.

## Wall Mount Packages

1. Be sure the wall can support the weight of the pump, bracket, hoses and accessories, as well as the stress caused during operation.
2. Position the wall bracket about 1.2-1.5 m (4-5 ft) above the floor. For ease of operation and service, make sure the pump air inlet, fluid inlet, and fluid outlet ports are easily accessible.
3. Using the wall bracket as a template, drill 10 mm (0.4 in.) mounting holes in the wall. Wall mounting dimensions are shown on page 30.
4. Attach the bracket to the wall. Use 3/8 in. (9 mm) screws that are long enough to keep the pump from vibrating during operation.

**NOTE:** Be sure the bracket is level.

## Components

See FIG. 1. **Components vary by package ordered.** Your package may include:

- A red-handled bleed-type master air valve (E) is required in your system to relieve air trapped between it and the air motor and gun when the valve is closed. Do not block access to the valve.
- The pump air regulator (H) controls pump speed and outlet pressure by adjusting the air pressure to the pump.
- The air relief valve (not shown) opens automatically to prevent over-pressurization of the pump.
- The gun air regulator (D) adjusts the air pressure to the spray gun (L).
- The spray gun (L) dispenses the fluid.
- The transparent hose (N, labeled “Air Hose Only”) provides the gun air supply.
- The red hose (M) provides the gun fluid supply.
- The suction hose (V) with strainer allows the pump to draw fluid from a 5 gallon (19 liter) pail. A fluid hopper with screen also is available.
- A fluid filter (P) with a 60 mesh (250 micron) stainless steel element filters particles from fluid as it leaves the pump.
- A fluid drain valve (W) relieves fluid pressure in the hose and gun.
- DataTrak (F) provides pump diagnostics and material usage information. See page 17.

## Air Line Accessories

Install the following accessories in the configuration shown in FIG. 1, using adapters as necessary.

- An air-line filter (B) removes harmful dirt and moisture from the compressed air supply.
- A second bleed-type air shutoff valve (A) isolates the air line accessories for servicing. Locate upstream from all other air line accessories.

## Grounding

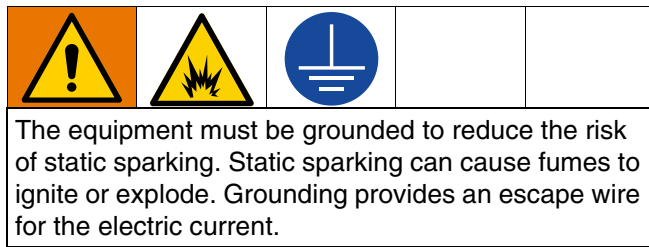

**Pump:** See FIG. 2. Verify that the ground screw (GS) is attached and tightened securely to the air motor. Connect the other end of the ground wire (S) to a true earth ground.

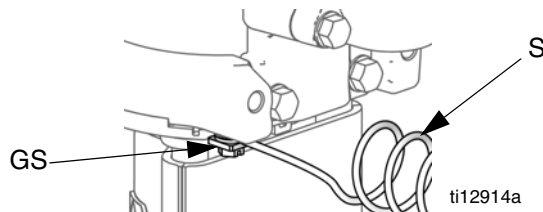

**FIG. 2. Ground screw and wire**

**Pump fluid hoses:** use only electrically conductive fluid hoses. Check electrical resistance of hoses. If total resistance to ground exceeds 25 megohms, replace hose immediately.

**Air compressor:** follow manufacturer's recommendations.

**Spray gun:** ground through connection to a properly grounded fluid hose and pump.

**Fluid supply container:** follow your local code.

**Object being sprayed:** follow your local code.

**Solvent pails used when flushing:** follow your local code. Use only metal pails, which are conductive, placed on a grounded surface. Do not place the pail on a non-conductive surface, such as paper or cardboard, which interrupts the grounding continuity.

To maintain grounding continuity when flushing or relieving pressure, hold a metal part of the spray gun firmly to the side of a grounded metal pail, then trigger the gun.

**DataTrak:** The DataTrak electronic monitoring system is required to be grounded. Do not remove it from its standard mounting location on the air control panel.

## Setup

1. See FIG. 1. Attach end of red fluid hose (M) to the fluid regulator outlet (X).
2. Attach one end of the air hose (N) to gun air regulator (D).
3. Attach remaining end of the air hose (N) to air inlet at base of gun (L).
4. Attach other end of red fluid hose (M) to gun.
5. Clip fluid and air hoses together with the supplied hose clips (qty. of 7). Space clips as needed.
6. Apply lens cover to both regulator gauge lenses.
7. Verify that suction hose fittings are tight.

## Gun Setup

Refer to **AirPro Pressure Feed Airspray Gun** manual (312414) for instructions on how to properly set up the spray gun.

# Operation

## Pressure Relief Procedure

 Follow the Pressure Relief Procedure whenever you see this symbol.



This equipment stays pressurized until pressure is manually relieved. To help prevent serious injury from pressurized fluid, such as splashing fluid and moving parts, follow the Pressure Relief Procedure when you stop spraying and before cleaning, checking, or servicing the equipment.

1. See FIG. 1. Turn off the bleed-type master air valve (E).
2. Hold a metal part of the gun firmly to a grounded metal waste container. Trigger the gun to relieve fluid pressure.
3. Open all fluid drain valves in the system, having a waste container ready to catch the drainage. Leave the drain valve(s) open until you are ready to spray again.
4. If you suspect the spray gun or hose is clogged or that pressure has not been fully relieved:
  - a. Slowly loosen the fluid hose coupling to relieve pressure gradually.
  - b. Clear the obstruction in the hose or spray gun.

## Flush the Pump Before First Use

The pump is tested with lightweight oil, which is left in to protect the pump parts. If the fluid you are using may be contaminated by the oil, flush it out with a compatible solvent. See **Flush the Pump** on page 15.

## Wet Cup

				
To avoid pinch hazard, do not operate the pump with the rod guard removed.				

Before starting, fill wet cup 1/3 full with Graco Throat Seal Liquid (TSL) or compatible solvent.

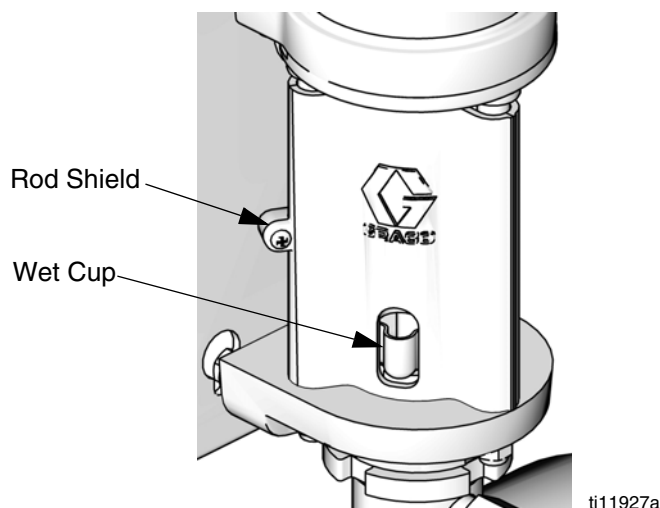

**FIG. 3. Wet Cup**

ti11927a

## Prime the Pump

1. Close gun air regulator (D) and pump air regulator (H) by turning knobs counterclockwise reducing pressure to zero. Close bleed-type air valve (E). Also verify that all drain valves (W) are closed.
2. Connect air supply line to bleed type master air valve (E).
3. Check that all fittings throughout system are tightened securely.
4. Position pail close to pump. Suction hose is 4 ft (1.2 m) long. Do not stretch hose tight; let it hang to assist fluid flow into pump.
5. Hold metal part of gun (L) firmly to side of grounded metal pail and hold trigger open.

**NOTE:** If your pump has DataTrak, see **DataTrak Operation** on page 18 or your separate NXT air motor manual for DataTrak instructions.

6. *DataTrak equipped units with runaway protection only:* enable the prime/flush function by pushing the prime/flush button on the DataTrak.
7. Open bleed-type air valve (E). Slowly turn pump air regulator (H) clockwise, increasing pressure until pump starts.
8. Cycle pump slowly until all air is pushed out and pump and hoses are fully primed.
9. *DataTrak equipped units with runaway protection only:* disable the prime/flush function by pushing the prime/flush button on the DataTrak.
10. Release gun trigger. The pump should stall against pressure.

### NOTICE

Never allow the pump to run dry of the fluid being pumped. A dry pump quickly accelerates to a high speed, possibly damaging itself. If your pump accelerates quickly, or is running too fast, stop it immediately and check the fluid supply. If the supply container is empty and air has been pumped into the lines, refill the container and prime the pump and the lines with fluid, or flush and leave it filled with a compatible solvent. Be sure to eliminate all air from the fluid system.

## Shutdown



Follow **Pressure Relief Procedure**, page 13.

Always flush the pump before the fluid dries on the displacement rod. See **Flush the Pump** on page 15.

# Maintenance

## Preventive Maintenance Schedule

The operating conditions of your particular system determine how often maintenance is required. Establish a preventive maintenance schedule by recording when and what kind of maintenance is needed, and then determine a regular schedule for checking your system.

Replace lens covers on regulator gauge lenses when dirt makes gauges difficult to read.

## Tighten Threaded Connections

Before each use, check all hoses for wear or damage. Replace as necessary. Check that all threaded connections are tight and leak-free.

## Flush the Pump



To avoid fire and explosion, always ground equipment and waste container. To avoid static sparking and injury from splashing, always flush at the lowest possible pressure.

Flush the pump:

- Before first use
- When changing colors or fluids
- Before repairing equipment
- Before fluid dries or settles out in a dormant pump (check the pot life of catalyzed fluids)
- At the end of the day
- Before storing the pump.

Flush at the lowest pressure possible. Flush with a fluid that is compatible with the fluid you are pumping and with the wetted parts in your system. Check with your fluid manufacturer or supplier for recommended flushing fluids and flushing frequency.

1. Follow **Pressure Relief Procedure**, page 13.
2. Place siphon tube in grounded metal pail containing cleaning fluid.
3. Close gun air regulator (D) and pump air regulator (H) by turning knobs counterclockwise, reducing pressure to zero.
4. Set pump to lowest possible fluid pressure, and start pump.
5. Hold a metal part of the gun firmly to a grounded metal pail.
6. *DataTrak equipped units with runaway protection only*: enable the prime/flush function by pushing the prime/flush button on the DataTrak.
7. Trigger gun. Flush system until clear solvent flows from gun.
8. *DataTrak equipped units with runaway protection only*: disable the prime/flush function by pushing the prime/flush button on the DataTrak.
9. Follow **Pressure Relief Procedure**, page 13.
10. Clean the spray gun and fluid filter element separately, then reinstall them.
11. Clean inside and outside of suction tube.

## Wet Cup

Fill the wet cup 1/3 full with Graco Throat Seal Liquid (TSL). Maintain level daily.

# Troubleshooting



1. Follow **Pressure Relief Procedure**, page 13, before checking or repairing pump.
2. Check all possible problems and causes before disassembling pump.

Problem	Cause	Solution
Pump fails to operate.	Restricted line or inadequate air supply; closed or clogged valves.	Clear line or increase air supply. Check that the valves are open.
	Obstructed fluid hose or gun; fluid hose ID is too small.	Open, clear*; use hose with larger ID.
	Fluid dried on the displacement rod.	Clean; always stop the pump at the bottom of its stroke; keep the wet-cup 1/3 filled with Graco throat seal liquid (TSL).
	Dirty, worn, or damaged air motor parts.	Clean or repair air motor. See NXT Air Motor manual 312796.
	DataTrak models only: Air valve cannot cycle because solenoid pin is extended.	Enable runaway protection (See <b>DataTrak Operation, Setup Mode</b> , page 18). Bleed air from motor. Press  on the DataTrak display to retract solenoid pin.
Pump operates, but output is low on both strokes.	Restricted line or inadequate air supply; closed or clogged valves.	Clear line or increase air supply. Check that the valves are open.
	Obstructed fluid hose or gun; fluid hose ID is too small.	Open, clear*; use hose with larger ID.
	Worn packings in displacement pump.	Replace packings. See Displacement Pump manual 312792.
Pump operates, but output is low on downstroke.	Held open or worn ball check valves or piston packings.	Clear valve; replace packings. See Displacement Pump manual 312792.
Erratic or accelerated pump speed.	Exhausted fluid supply.	Refill and prime.
	Held open or worn ball check valves or packings.	Clear valve, replace packings; see Displacement Pump manual 312792.
Fluid being pumped is visible in the TSL reservoir.	Worn throat packings.	Replace throat packings. See Displacement Pump manual 312792.

\* To determine if the fluid hose or gun is obstructed, follow the **Pressure Relief Procedure** on page 13. Disconnect the fluid hose from the pump and place a container at the pump fluid outlet to catch any fluid. Turn on the air just enough to start the pump. If the pump starts when the air is turned on, the obstruction is in the hose or gun.



# DataTrak Controls and Indicators

## Key for FIG. 4

- AA Runaway Limit, in cycles per minute (user settable; 00=OFF)
- AB Lower Displacement (user settable)
- AC Flow Rate Units (user settable to  $\updownarrow$ /min, gpm [US], gpm [Imperial], oz/min [US], oz/min [Imperial], l/min, or cc/min)
- AD LED (fault indicator when lit)
- AE Display
- PF Prime/Flush Key (Enables Prime/Flush mode. While in Prime/Flush mode, runaway protection is disabled and the batch totalizer [BT] will not count.) LED will flash while in Prime/Flush mode.
- RK Reset Key (Resets faults. Press and hold for 3 seconds to clear the batch totalizer.) Push to toggle between flow rate and cycle rate. With runaway protection enabled, push to extend and retract the solenoid pin.
- CF Cycle/Flow Rate
- BT Batch Totalizer
- GT Grand Totalizer
- RT Runaway Toggle (enable/disable)
- UT E1 Toggle
- DT E2 Toggle
- ST E5 Toggle

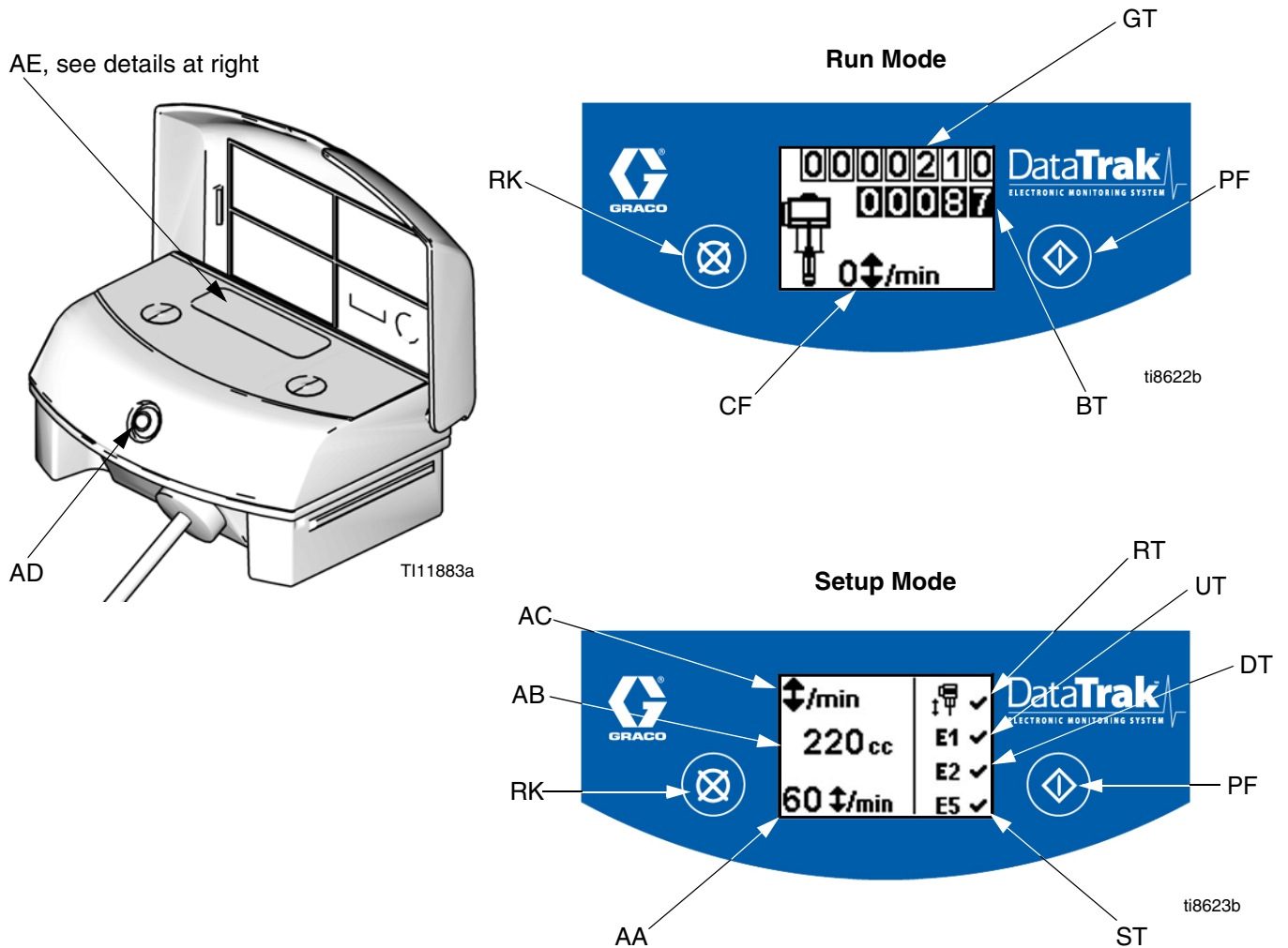





FIG. 4. DataTrak Controls and Indicators

# DataTrak Operation

**NOTE:** The display (AE) will turn off after 1 minute to save battery life. Press any key to wake up the display.

<b>NOTICE</b>
To prevent damage to the soft key buttons, do not press the buttons with sharp objects such as pens, plastic cards, or fingernails.

## Setup Mode

1. See FIG. 4. Press and hold  for 5 seconds until Setup menu appears.
2. To enter settings for runaway (if equipped), lower size, and flow rate units, and to enable runaway, E1, E2, and E5 error options, press  to change the value, then  to save the value and move the cursor to the next data field. See page 20 for a description of E1, E2, and E5 error codes.

**NOTE:** Graco recommends setting runaway (if equipped) to 60 . All DataTrak modules are shipped with runaway protection not enabled.

**NOTE:** When runaway, E1, E2, and E5 error options are enabled, a  will appear on the setup screen. See FIG. 4.

3. Move the cursor to the E5 error enable option field, then press  once more to exit Setup mode.

## Run Mode

### Pump Runaway

**NOTE:** DataTrak is available with and without runaway protection.

1. See FIG. 4. If pump runaway occurs, the runaway solenoid will actuate, stopping the pump. The LED (AD) will flash and the display (AE) will indicate a runaway condition (see Table 1). The display will cycle through six instruction screens.

2. Runaway Screens 1 and 2: To reset the runaway solenoid, close the master air valve (E). Wait for air to completely bleed off the air motor.

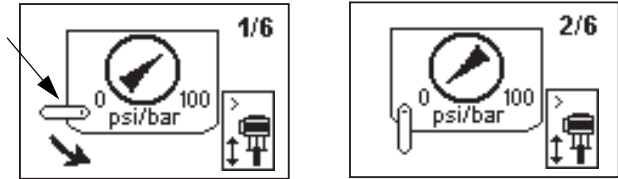

3. Runaway Screens 3 and 4: After the air is bled off, push the solenoid release button (J) down to reset the air valve. The button will pop back up when the air valve is repressurized.

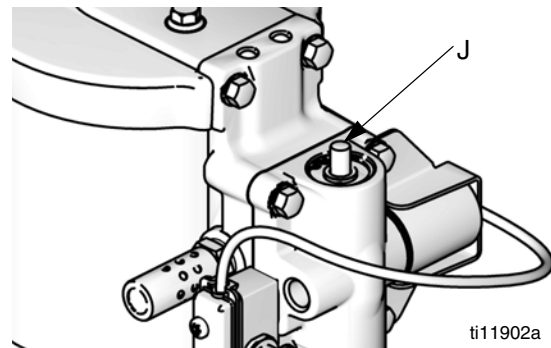
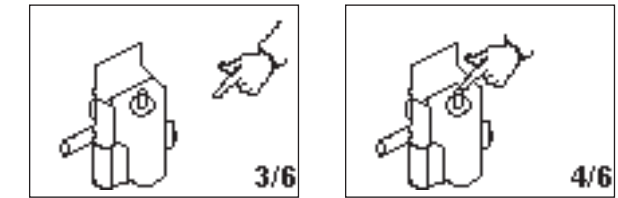

**FIG. 5. Solenoid Release Button**

4. Runaway Screens 5 and 6: Press  to clear the diagnostic code and reset the runaway solenoid.

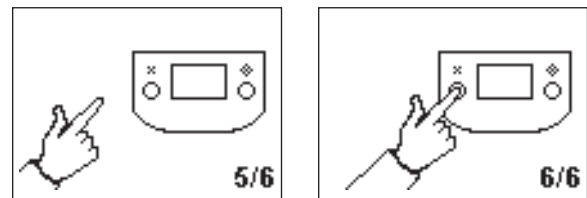

5. Open bleed-type master air valve (E) to restart pump.

**NOTE:** To disable runaway monitoring, go to setup mode and set runaway value to 0 (zero) or toggle (RT) off  (see FIG. 4).

## Prime/Flush

1. See FIG. 4. To enter Prime/Flush mode, press any key to wake up the display, then press . The Prime/Flush symbol will appear in the display and

the LED will flash

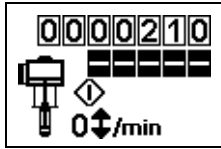

2. While in Prime/Flush mode, runaway protection is disabled and the batch totalizer (BT) will not count. The grand totalizer (GT) continues to count.
3. To exit Prime/Flush mode, press any key to wake up the display, then press . The Prime/Flush symbol will disappear from the display and the LED will stop flashing.

## Counter/Totalizer

See FIG. 4. The last digit of the batch totalizer (BT) represents tenths of gallons or liters. To reset the totalizer, press any key to wake up the display, then press and hold  for 3 seconds.

- If AC is set to gallons or ounces, BT and GT display gallons.
- If AC is set to liters or cc, BT and GT display liters.
- If AC is set to cycles, BT and GT display cycles.

Press  to toggle between flow rate units and cycles. A letter under the BT display indicates that both BT and GT are displaying gallons (g) or liters (l). No letter means both BT and GT are displaying cycles.

## Display

See FIG. 4. The display (AE) will turn off after 1 minute of inactivity in Run mode or 3 minutes in Setup mode. Press any key to wake up the display.

**NOTE:** DataTrak will continue to count cycles when display is off.

**NOTE:** The display (AE) may turn off if a high-level static discharge is applied to the DataTrak. Press any key to wake up the display.

## Diagnostics

DataTrak can diagnose several problems with the pump. When the monitor detects a problem, the LED (AD, FIG. 4) will flash and a diagnostic code will appear on the display. See Table 1.

To acknowledge the diagnosis and return to the normal operating screen, press  once to wake up the display, and once more to clear the diagnostic code screen

**Table 1: Diagnostic Codes**







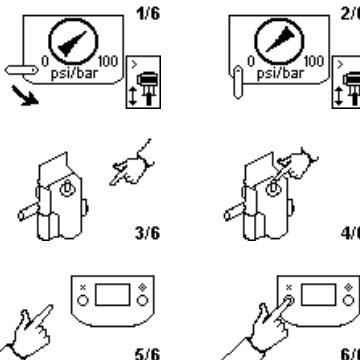

Symbol	Code	Code Name	Diagnosis	Cause
		Runaway (DataTrak only)	Pump running faster than set runaway limit.	<ul style="list-style-type: none"> <li>• Increased air pressure.</li> <li>• Increased fluid output.</li> <li>• Exhausted fluid supply.</li> </ul>

Table 1: Diagnostic Codes

Symbol	Code	Code Name	Diagnosis	Cause
 E1	E-1	Diving Up	Leak during upstroke.	Worn piston valve or packings.
 E2	E-2	Diving Down	Leak during downstroke.	Worn intake valve.
 E3	E-3	Low Battery	Battery voltage too low to stop runaway.	Low battery. Replace battery; see page 22.
 E4	E-4	Service Component 1 (units with runaway protection only)	Problem with stopping runaway.	<ul style="list-style-type: none"> <li>Damaged solenoid.</li> <li>Damaged valve carriage.</li> <li>Runaway (RT, FIG. 4) protection may be enabled with pump that is not equipped with a runaway solenoid valve. Enter setup screen and disable runaway protection.</li> </ul>
 E4	E-4	Disconnected Solenoid (units with runaway protection only)	<p>Solenoid is disconnected.</p> <p>Solenoid is not engaging piston cup (112).</p>	<ul style="list-style-type: none"> <li>Solenoid unplugged.</li> <li>Damaged solenoid wires.</li> <li>Bracket and solenoid not tight against air valve housing.</li> </ul>
 E5	E-5	Service Component 2	Problem with sensing valve movement.	<ul style="list-style-type: none"> <li>Sensors unplugged.</li> <li>Sensors mounted incorrectly.</li> <li>Damaged sensors.</li> <li>Damaged valve carriage.</li> </ul>
 E6 Fuse 63 mA	E-6	Blown Fuse	Fuse is blown. Replace fuse; see page 22.	<ul style="list-style-type: none"> <li>Faulty solenoid or solenoid wiring.</li> <li>Extreme temperatures (above 140°F [60°C]).</li> <li>Runaway (RT, FIG. 4) protection may be enabled with pump that is not equipped with a runaway solenoid valve. Enter setup screen and disable runaway protection.</li> </ul>

## Replace DataTrak Battery or Fuse

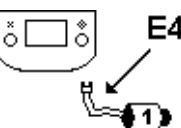
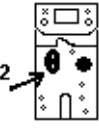

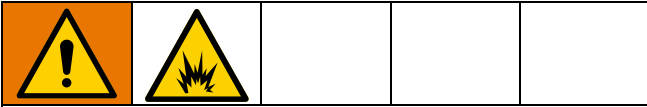
To reduce the risk of fire and explosion, the battery and fuse must be replaced in a non-hazardous location.

Use only an approved replacement battery, shown in TABLE 2, and an approved fuse, shown in TABLE 3. Use of an unapproved battery or fuse will void Graco's warranty and Intertek and Ex approvals.

4. Remove two screws on back of module to access battery.
5. See FIG. 8. Disconnect the used battery and replace with an approved battery from TABLE 2.

Table 2. Approved Batteries
Energizer® brand alkaline # 522
Varta® brand alkaline # 4922
Ultralife® brand lithium # U9VL
Duracell® brand alkaline # MN1604

## Replace Battery

1. Unscrew cable from the back of the reed switch assembly. See FIG. 6.
2. Remove the cable from the two cable clips.

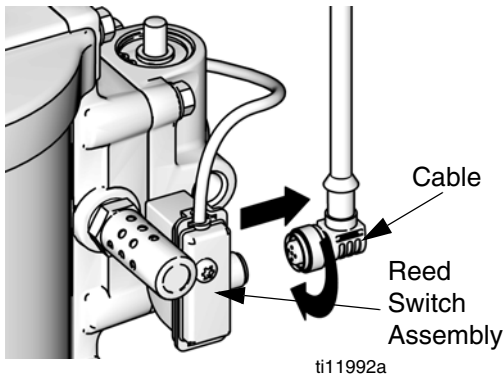

FIG. 6. Disconnect DataTrak

3. Remove DataTrak module from bracket. See FIG. 7. Take module and attached cable to a non-hazardous location.

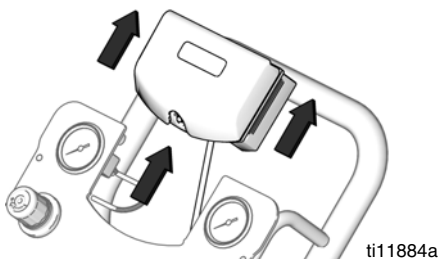

FIG. 7. Remove DataTrak

### Replace Fuse

1. Remove the screw, metal strap, and plastic holder.
2. Pull the fuse away from the board.
3. Replace with an approved fuse from TABLE 3.

<b>DataTrak Part Number</b>	<b>Series*</b>	<b>Fuse Required ‡</b>
289822	A or B	24C580
	C and later	24V216
All other part numbers	A	24C580
	B and later	24V216

\* FIG. 8 shows where to find the Series letter.

‡ Graco Part Numbers

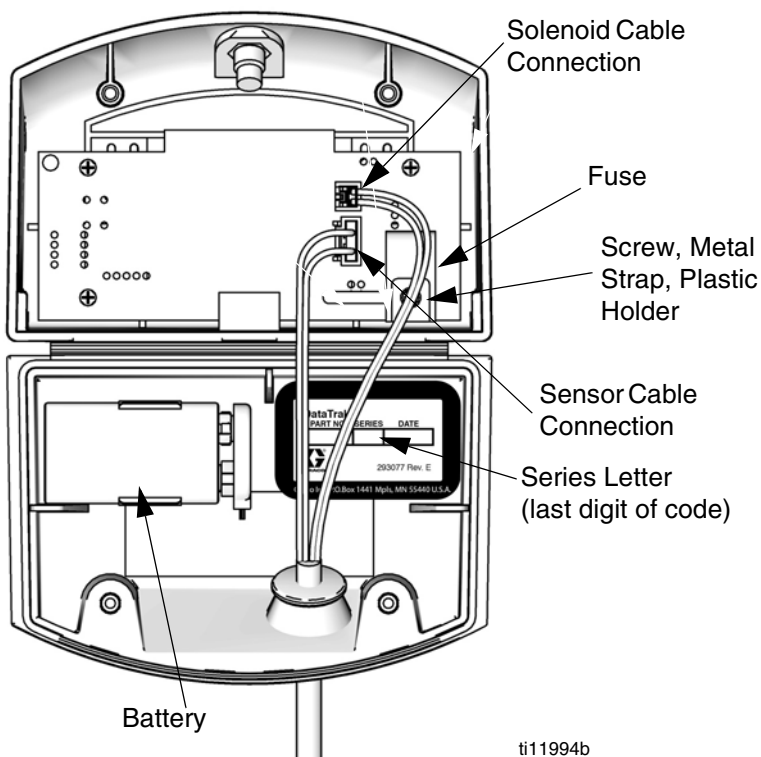

ti11994b

**FIG. 8. DataTrak Battery and Fuse Location**

# Parts Cart Mount

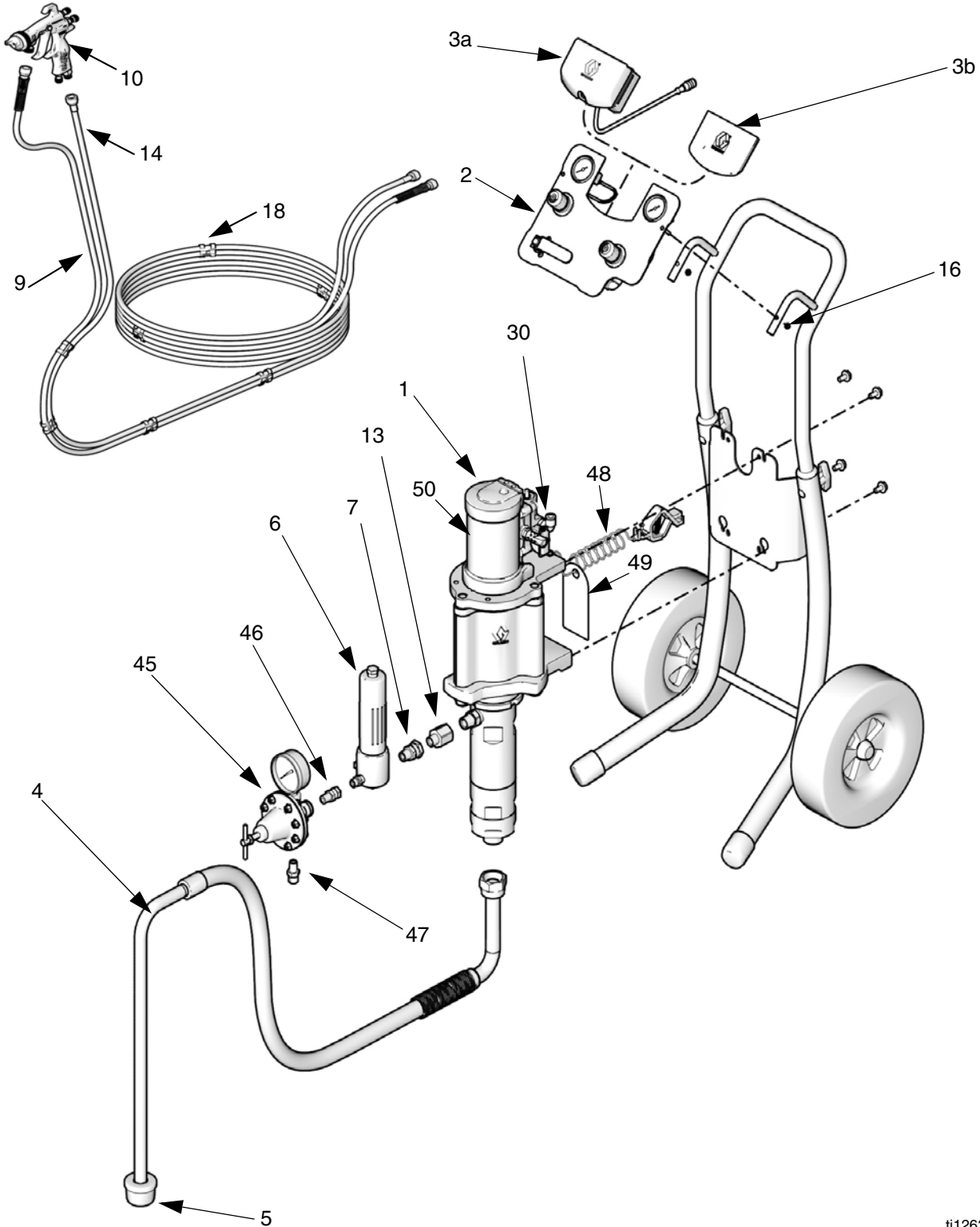

ti12632a



# Wall Mount

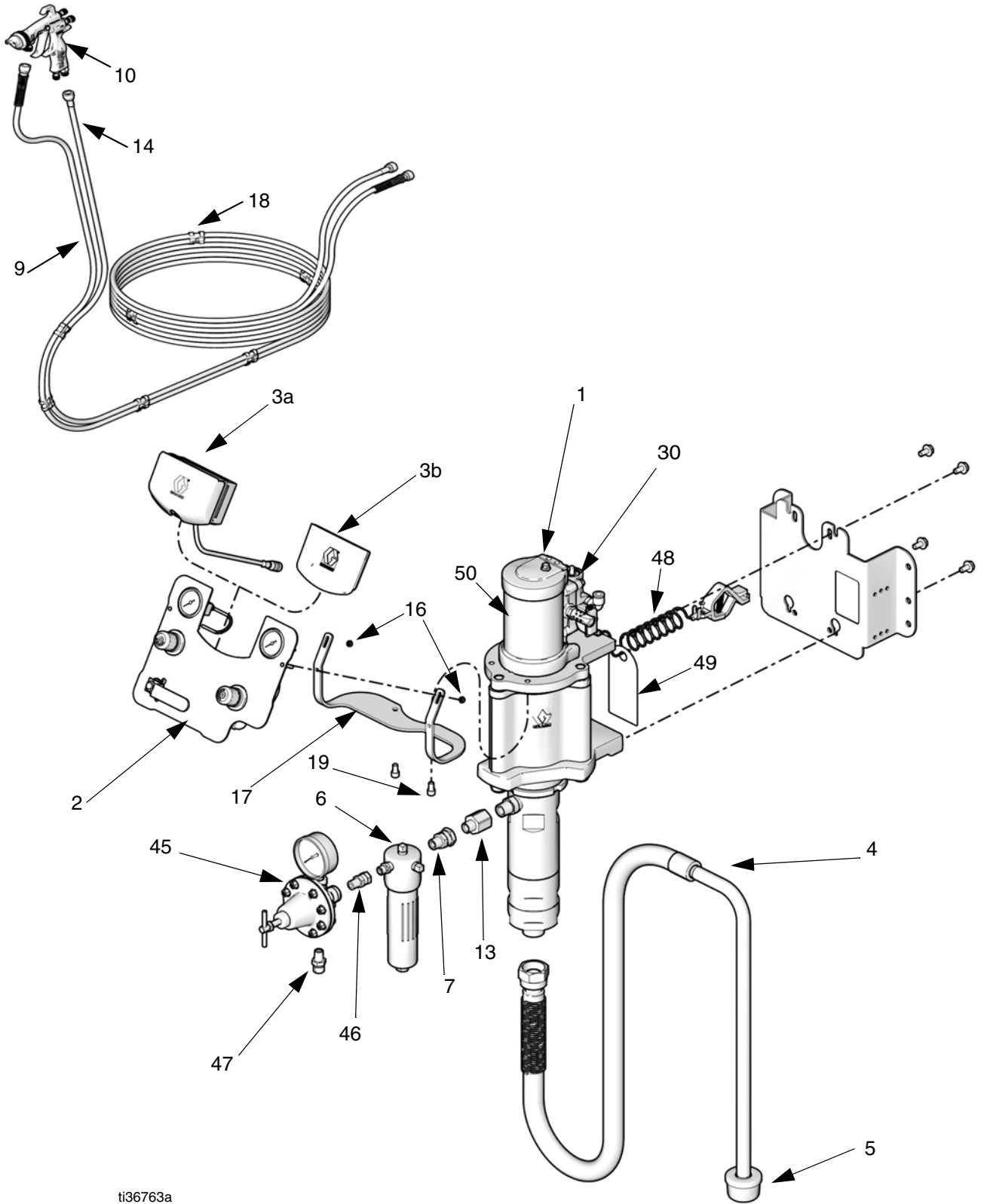

ti36763a

**NOTE:**

- See page 27 for mounting kits for all packages.
- See page 28 for repair parts and accessories.

**G03xxx Models**

This list includes all possible parts for G03xxx packages. See page 27 to check whether a part is included in your particular package.

Ref.	Part	Description	Qty
1	W03EAS W03EBS	PUMP, assembly M02LN0 x LW125B M02LT0 x LW125B	1
2	25E459	PANEL, air controls pump and gun; <i>see page 28</i>	1
3a	289822	DATATRAK, assembly; <i>see manual 313541</i>	1
3b	277794	INSERT, panel	1
4	24A231 24A232	HOSE, suction (includes Part 5) cart mount packages wall mount packages	1
5	256426	STRAINER, package of 10 (included with Part 4)	1
6	223160	FILTER, fluid	1
7	235208	FITTING, union (included with Part 6)	1
9	235339	HOSE, fluid, coupled, 25 ft (packages with gun),	1
10	288938 288931 288945	GUN, AirPro, HVLP (Models G03X04 and G03X05) GUN, AirPro, Conventional (Models G03X06 and G03X07) GUN, AirPro, Compliant (Models G03X08 and G03X09)	1

Ref.	Part	Description	Qty
13	121237	ADAPTER, 3/8 nptm x 1/2 nptf	1
14	244448	HOSE, coupled, air	1
16	105332	NUT, lock, M5 x 0.08	2
17	19A605	BRACKET, air control, wall mount only	1
18	120706	TUBE, T-clip	1
19	116940	SCREW, socket head cap, 5/16-18, wall mount only	1
30	121141	FITTING, swivel elbow, 3/8 t X 1/4 mnpt	1
45	241976	REGULATOR, pressure fluid G03C01 to G03C13 models	1
46	17K624	FITTING, swivel, 1/4 npt, 316 sst	1
47	112494	NIPPLE, adapter, 1/4 nps(m) x 1/4 npt	1
48	238909	WIRE, grounding assembly	1
49▲	290079	LABEL, safety, ground wire	1
50▲	15M302	LABEL, cover, motor	1

▲ Replacement Safety labels, tags, and cards are available at no cost.

----- Not sold separately.

# Kits

## Wall Mount Kit 24A578

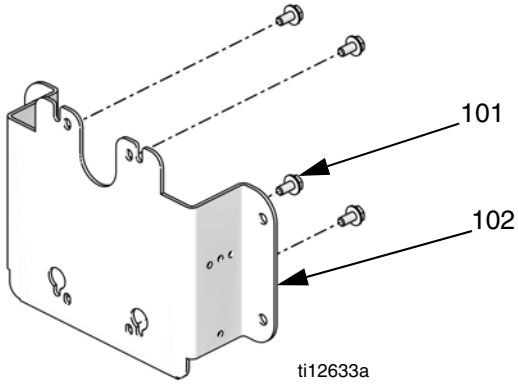

Ref.	Description	Qty
101	SCREW, cap, M8 x 1.25	4
102	PLATE, wall mount	1

## Cart Mount Kit 289694

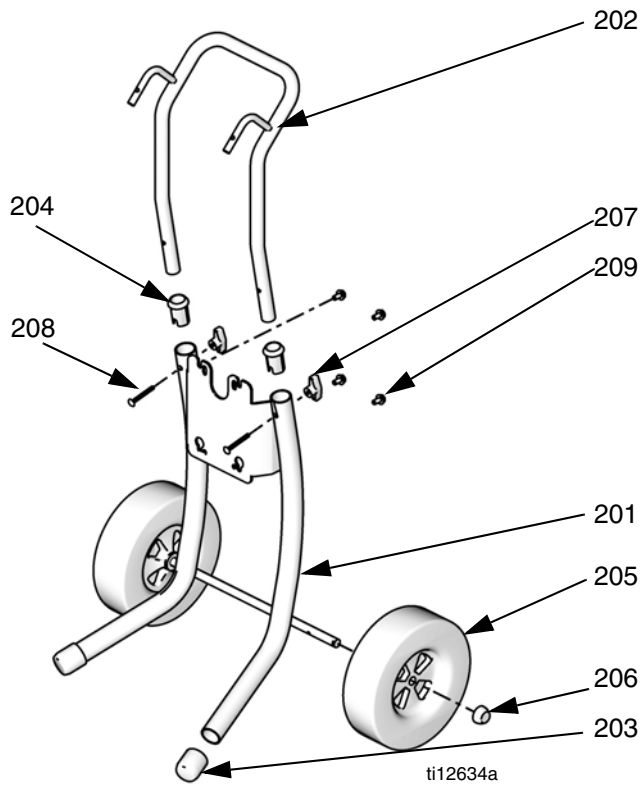

Ref.	Part	Description	Qty
201	-----	CART, frame	1
202	-----	HANDLE, cart	1
203	15C871	CAP, leg	2
204	-----	SLEEVE, cart handle	2
205	119451	WHEEL, semi-pneumatic	2
206	119452	CAP, hub	2
207	115480	KNOB, t-handle	2
208	116630	SCREW, carriage	2
209	111799	SCREW, cap, M8 x 1.25	4

----- Not sold separately.

## Pump and Gun Control Panel Kits

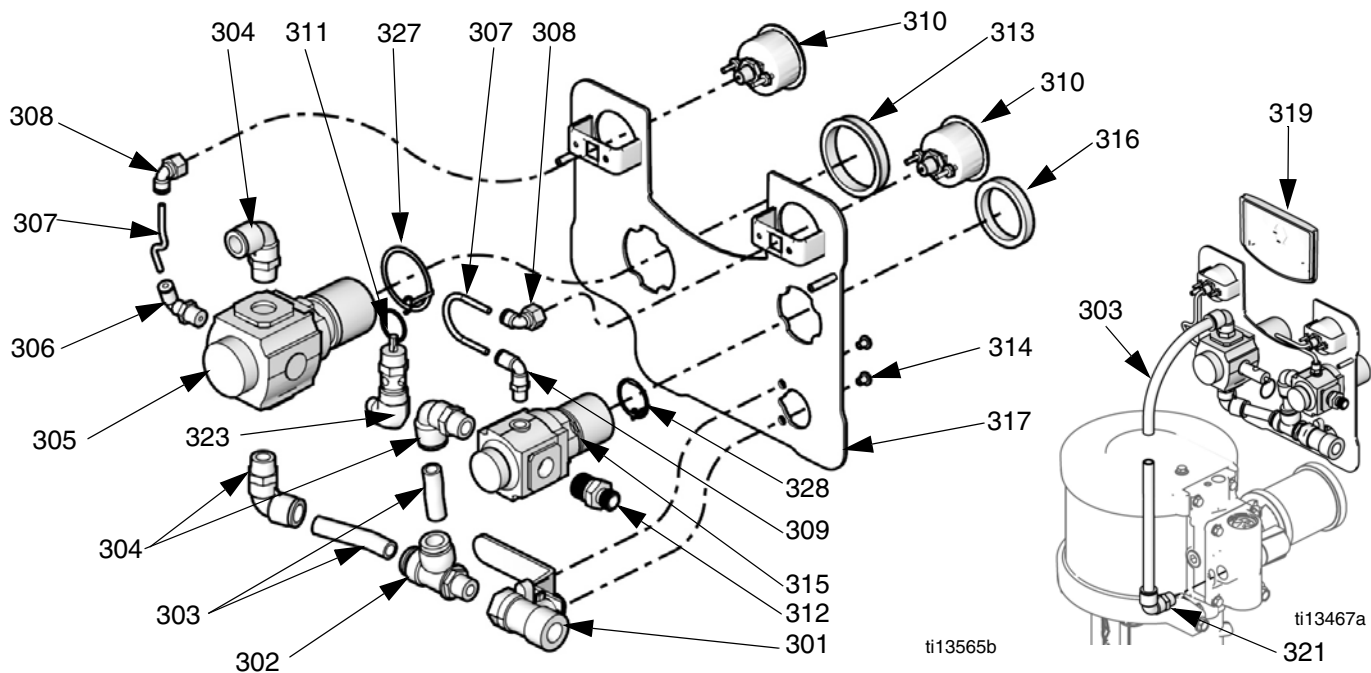

### M02xxx air motors

Kit 25E459

Ref.	Part	Description	Qty
301	114362	VALVE, ball, 3/8-18 npt(f)	1
302	-----	SWIVEL, tee	1
303	-----	TUBE, 3/8 OD, cut to fit, order Tubing Kit 24D496	1.3 ft.
304	121141	ELBOW, swivel, 3/8T x 1/4 npt(m)	3
305	15T499	REGULATOR, air, pump, 1/4 npt	1
306	15T866	ELBOW, swivel, 5/32T x 1/8 npt	1
307	-----	TUBE, black, cut to fit, order Tubing Kit 24D496	4 in.
308	15T498	SWIVEL, 90°, 5/32T x 1/8 npt(f)	2
309	15T866	ELBOW, swivel, 5/32T x 1/8 npt	1
310	15T500	GAUGE, pressure	2
311	116306	VALVE, safety, 50 psi	1

Ref.	Part	Description	Qty
312	162453	NIPPLE, adapter, 1/4 nps(m) x 1/4 npt	1
313	115244	NUT, regulator	2
314	114381	SCREW, cap, button head	2
315	15T499	REGULATOR, air, gun, 1/4 npt	1
316	115244	NUT, regulator	1
317	-----	PANEL	1
319	-----	INSERT	1
320	105332	NUT, lock (not shown)	2
321	121141	ELBOW, 3/8T x 1/4 npt(m)	1
322	-----	COVER, lens, 12 sticker sheet (not shown), order Kit 24A540 for 5 sheets	1
323	-----	ELBOW, 1/4 npt(f) x 1/8 npt(m)	1
327	24P812	RING, grounding	1
328	24P812	RING, grounding	1

----- Not sold separately.

## DataTrak

**NOTE:** See DataTrak manual, 313541, for all DataTrak related part numbers and kit information, including the reed switch and solenoid.

## Drain Valve Kit 256425

Includes drain valve, coupling, and hose.

## Reinforced PTFE V-Packing Kits

**NOTE:** See manual 312792 for information related to optional kits with reinforced PTFE seals for use with materials that cause chemical compatibility concerns with UHMWPE, such as acid catalyst materials.

## Wall Bracket Mounting Dimensions

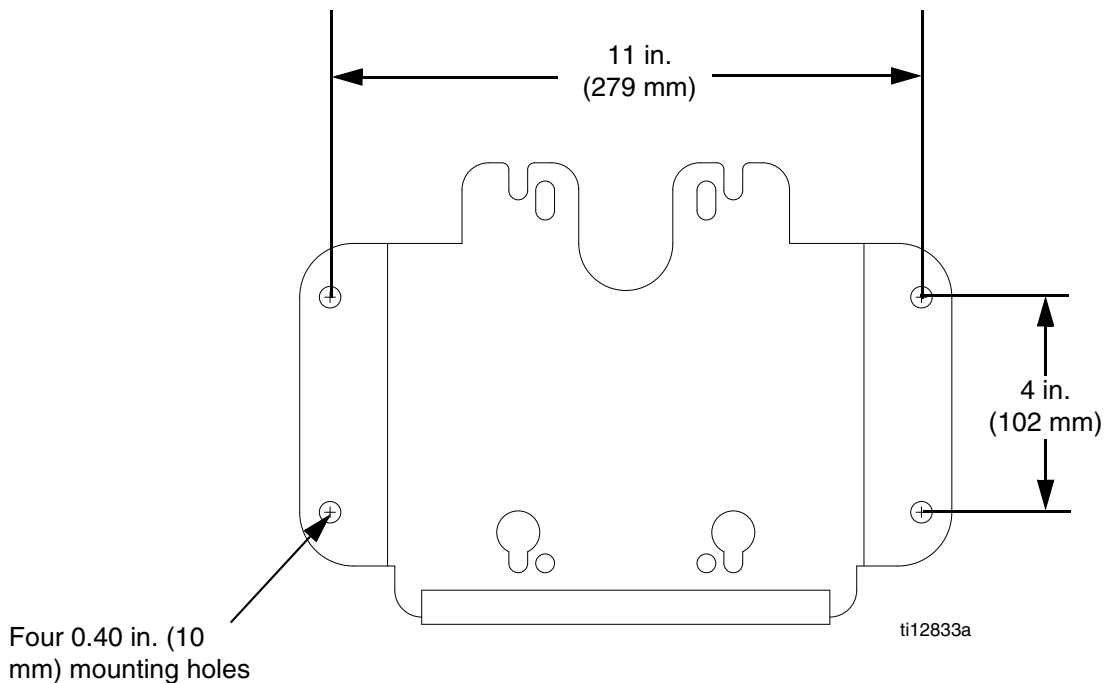

## Technical Specifications

Maximum fluid working pressure. . . . .	120 psi (.83 MPa, 8.3 bar)
Maximum pump air inlet pressure. . . . .	50 psi (.34 MPa, 3.4 bar)
Maximum gun air inlet pressure . . . . .	120 psi (.83 MPa, 8.3 bar)
Ratio . . . . .	3:1
Air inlet size. . . . .	3/8-18 npt(f)
Ambient air temperature range . . . . .	35°F–120°F (2°C–49°C)
Maximum fluid temperature. . . . .	160°F (71°C)
Sound data . . . . .	See Technical Data in air motor manual 312796.
Wetted parts . . . . .	Displacement pump: Stainless steel, tungsten carbide with 6% nickel, UHMWPE, PTFE, Spray gun: See <b>AirPro Pressure Feed Airspray Gun</b> manual 312414. Fluid hoses: stainless steel, nylon Suction assembly: stainless steel, nylon Fluid filter: See <b>Fluid Outlet Filter</b> manual 307273.



# Graco Standard Warranty

Graco warrants all equipment referenced in this document which is manufactured by Graco and bearing its name to be free from defects in material and workmanship on the date of sale to the original purchaser for use. With the exception of any special, extended, or limited warranty published by Graco, Graco will, for a period of twelve months from the date of sale, repair or replace any part of the equipment determined by Graco to be defective. This warranty applies only when the equipment is installed, operated and maintained in accordance with Graco's written recommendations.

This warranty does not cover, and Graco shall not be liable for general wear and tear, or any malfunction, damage or wear caused by faulty installation, misapplication, abrasion, corrosion, inadequate or improper maintenance, negligence, accident, tampering, or substitution of non-Graco component parts. Nor shall Graco be liable for malfunction, damage or wear caused by the incompatibility of Graco equipment with structures, accessories, equipment or materials not supplied by Graco, or the improper design, manufacture, installation, operation or maintenance of structures, accessories, equipment or materials not supplied by Graco.

This warranty is conditioned upon the prepaid return of the equipment claimed to be defective to an authorized Graco distributor for verification of the claimed defect. If the claimed defect is verified, Graco will repair or replace free of charge any defective parts. The equipment will be returned to the original purchaser transportation prepaid. If inspection of the equipment does not disclose any defect in material or workmanship, repairs will be made at a reasonable charge, which charges may include the costs of parts, labor, and transportation.

**THIS WARRANTY IS EXCLUSIVE, AND IS IN LIEU OF ANY OTHER WARRANTIES, EXPRESS OR IMPLIED, INCLUDING BUT NOT LIMITED TO WARRANTY OF MERCHANTABILITY OR WARRANTY OF FITNESS FOR A PARTICULAR PURPOSE.**

Graco's sole obligation and buyer's sole remedy for any breach of warranty shall be as set forth above. The buyer agrees that no other remedy (including, but not limited to, incidental or consequential damages for lost profits, lost sales, injury to person or property, or any other incidental or consequential loss) shall be available. Any action for breach of warranty must be brought within two (2) years of the date of sale.

**GRACO MAKES NO WARRANTY, AND DISCLAIMS ALL IMPLIED WARRANTIES OF MERCHANTABILITY AND FITNESS FOR A PARTICULAR PURPOSE, IN CONNECTION WITH ACCESSORIES, EQUIPMENT, MATERIALS OR COMPONENTS SOLD BUT NOT MANUFACTURED BY GRACO.** These items sold, but not manufactured by Graco (such as electric motors, switches, hose, etc.), are subject to the warranty, if any, of their manufacturer. Graco will provide purchaser with reasonable assistance in making any claim for breach of these warranties.

In no event will Graco be liable for indirect, incidental, special or consequential damages resulting from Graco supplying equipment hereunder, or the furnishing, performance, or use of any products or other goods sold hereto, whether due to a breach of contract, breach of warranty, the negligence of Graco, or otherwise.

## Graco Information

For the latest information about Graco products, visit [www.graco.com](http://www.graco.com).

For patent information, see [www.graco.com/patents](http://www.graco.com/patents).

**TO PLACE AN ORDER**, contact your Graco distributor or call to identify the nearest distributor.

**Phone:** 612-623-6921 **or Toll Free:** 1-800-328-0211 **Fax:** 612-378-3505

*All written and visual data contained in this document reflects the latest product information available at the time of publication. Graco reserves the right to make changes at any time without notice.*

Original instructions. This manual contains English. MM 3A7003

**Graco Headquarters:** Minneapolis

**International Offices:** Belgium, China, Japan, Korea

**GRACO INC. AND SUBSIDIARIES • P.O. BOX 1441 • MINNEAPOLIS MN 55440-1441 • USA**  
**Copyright 2019, Graco Inc. All Graco manufacturing locations are registered to ISO 9001.**

[www.graco.com](http://www.graco.com)  
Revision B, November 2019